

Notes:

1. Currently, the number of loops as shown in this photograph of STS 4 is: **15** and the number of different shock cord lengths is: **4**.
2. The original **1st cable loop** was divided (by ThPA personnel) into 2 more loops, in order to resolve operational issues with festoon movement (due to the extensive length of the cable loop, its lower part was swinging and impacting the operator's cabin). This is why the total number of loops is currently 15.
See comments below regarding this **1st cable loop** modification.

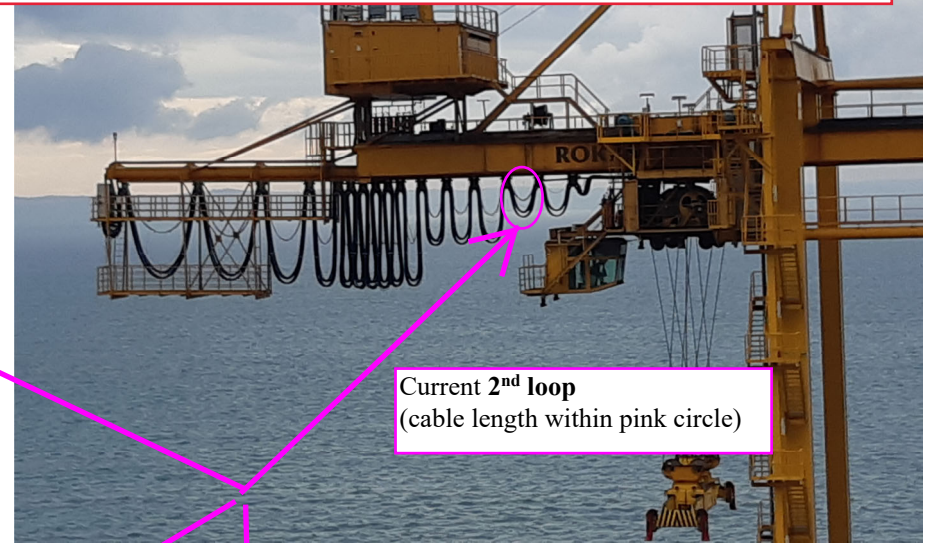
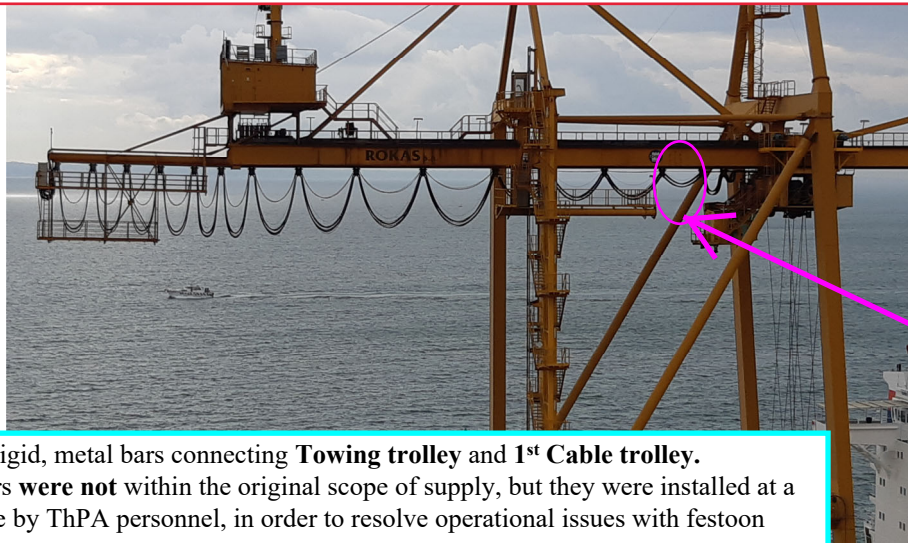

Current 2nd loop
(cable length within pink circle)

Two (2) rigid, metal bars connecting **Towing trolley** and **1st Cable trolley**. These bars **were not** within the original scope of supply, but they were installed at a later stage by ThPA personnel, in order to resolve operational issues with festoon movement.

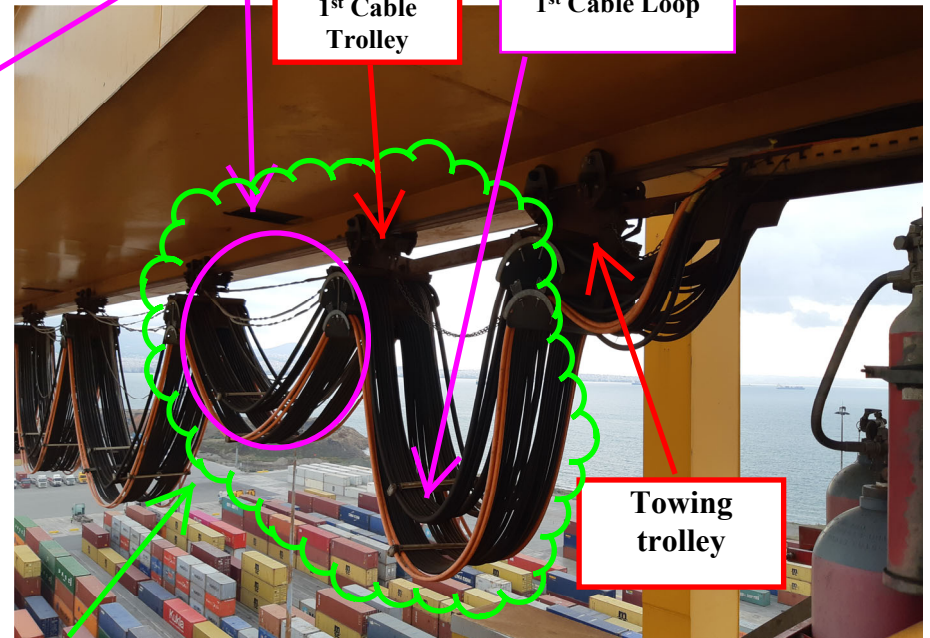
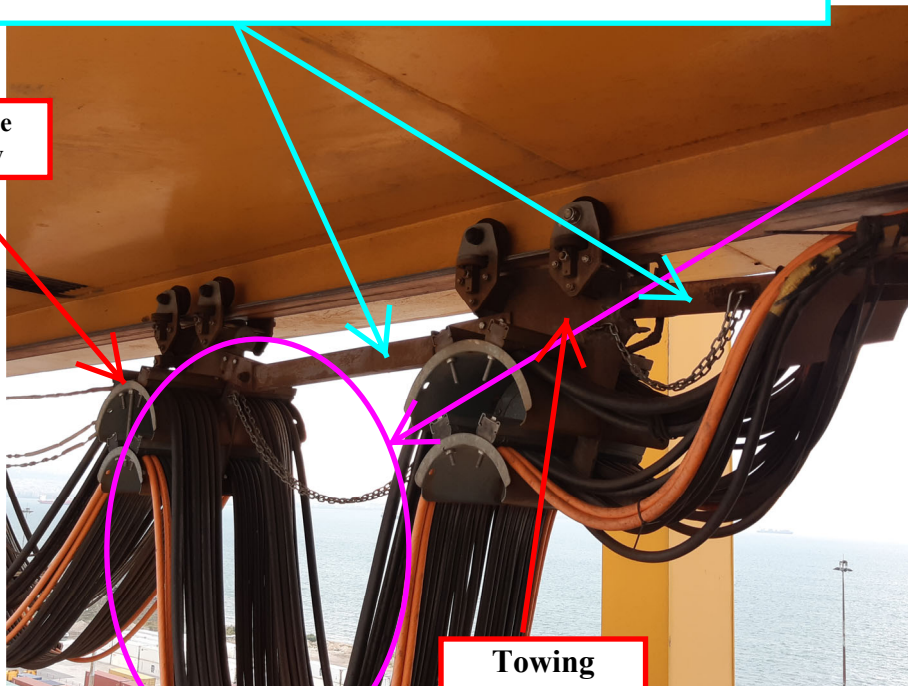

Originally, this cable length included within the green cloud, was actually the **1st cable loop**. At a later stage, this loop was divided (by ThPA personnel) into 2 more loops, as it is shown in this photograph.

Copyright at these designs and all interests, which are entrusted to the receiver, remains at any time to our company. Without our written permission they may not be copied, multiplied, communicated third persons or made accessible.

Das Urheberrecht an diesen Zeichnungen und allen Beilagen, die den Empfänger anvertraut sind, verbleibt jederzeit unserer Firma. Ohne unsere schriftliche Genehmigung dürfen sie nicht kopiert, vervielfältigt, dritten Personen mitgeteilt oder zugänglich gemacht werden.

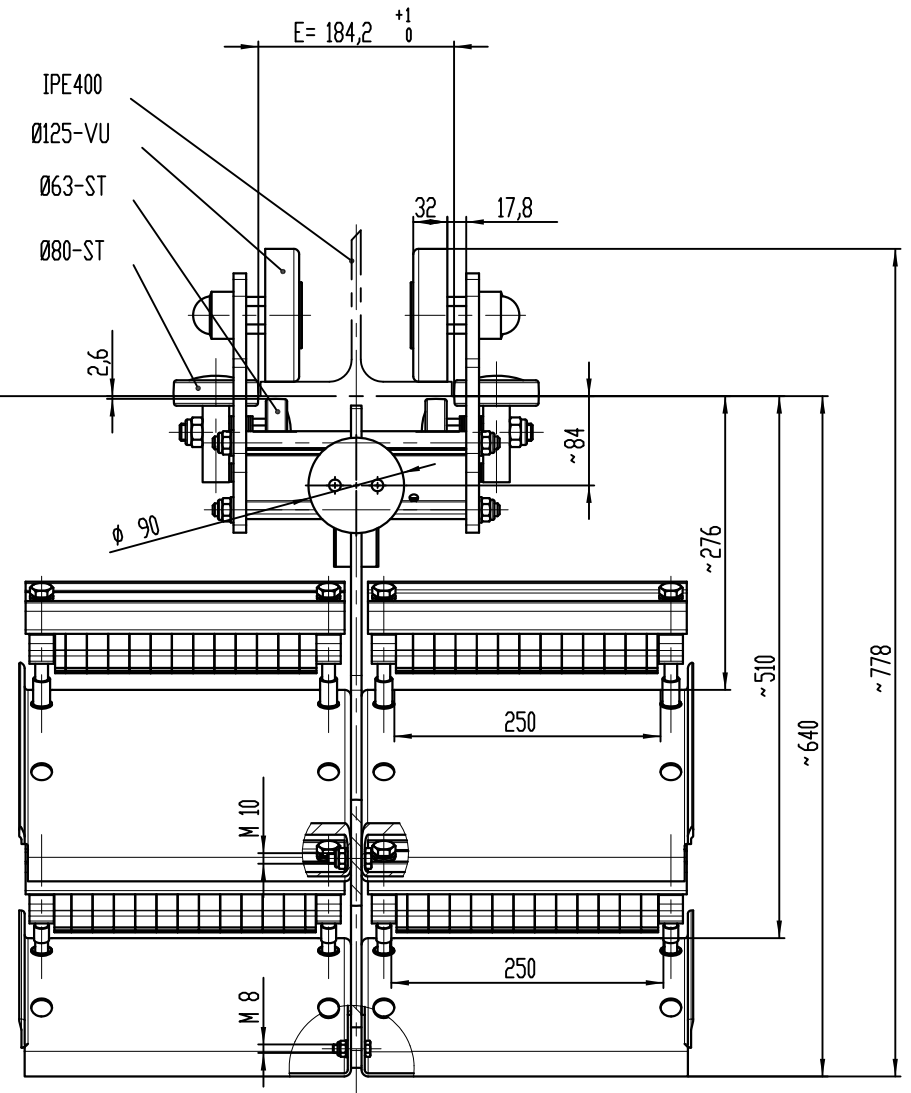
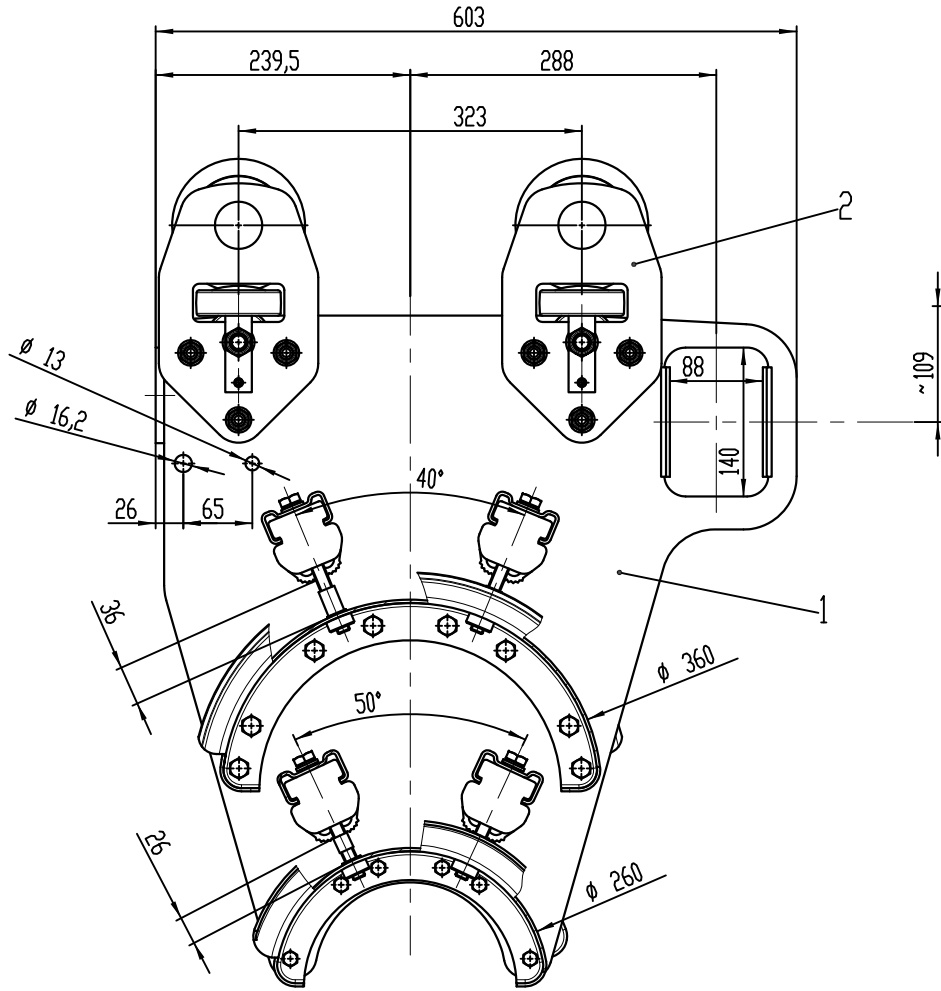

Material number: 3118148		$\sqrt{\text{w}} = \sqrt{\text{Rz100}}$ $\sqrt{\text{v}} = \sqrt{\text{Rz 25}}$ $\sqrt{\text{v}} = \sqrt{\text{Rz 6,3}}$	Allgemein-toleranz General tolerance ISO 2768-mK	Maßstab: Scale: 1:5	Gewicht: Weight: 86.980 KG	
			Material: ST			
			MITNEHMERWAGEN Ø360/Ø260X250 IPE400 TOWING TROLLEY Ø360/Ø260X250 IPE400			
			03-M066-0160			
Rev.	Modification	Date	Name			
-		25.11.2011	STBR	Blatt Sheet 1		
				1 Bl. Sh.		

